

PNA-20X Negative Feedback Avalanche Diodes (NFADs)

Product Features

- **Single photon sensitivity**
- **SWIR (1000 – 1700 nm) response**
- **High gain and low noise**
- **Fast response with precise timing**
- **Compact and robust**
- **Simple readout**



Princeton Lightwave's PNA-20X series NFAD is a new type of photon-counting device consisting of InGaAs/InP avalanche diodes with monolithically integrated negative feedback. PLI's patented approach to the integration of negative feedback resistors provides stable high-performance single photon response in Geiger mode operation. Leveraging the best-in-class performance of PLI's single photon avalanche diode (SPAD) technology, PLI's NFAD has excellent photon-counting capability in the shortwave infrared (SWIR) band, with high internal gain (10^5 to 10^6) and very consistent pulse response distributions. These detectors also have fast response coupled with excellent time resolution. Devices with single discrete active regions provide low dark count rate, and devices based on multiple connected active regions provide large detection area and photon number resolution.

Applications

- **Laser Radar (LADAR) and Ranging**
- **Free-space optical communications**
- **Fluorescence measurements**
- **Environmental analysis**
- **Biomedical devices**

PLI NFAD devices are available in three different active region formats:

- NFAD-1: discrete device
- NFAD-4: 2×2 active region format
- NFAD-16: 4×4 active region format

When multiple active regions are present, they are connected in parallel and provide output signals on a single pair of anode/cathode connections.

PLI NFADs are provided in two different package types.

- PNA-200: 3-pin TO-46 style package,
- PNA-208: 6-pin TO-8 style package with three-stage thermoelectric cooler (TEC)

Both package versions are hermetic and incorporate packaging designs and processes that ensure robust, reliable operation in harsh environments. PLI is an ISO-9001 certified company and develops and manufactures components to demanding MIL and telecommunications quality standards.

TYPICAL PERFORMANCE SPECIFICATIONS

Operating conditions: device temperature $T = 240$ K; reverse-biased

Parameter Description	Symbol	NFAD-1	NFAD-4	NFAD-16	Units
Active region format		discrete	2×2	4×4	-
Detection area dimensions		$\varnothing 22$	72×72	156×156	μm
Fill factor	FF	100	29	25	%
Spectral response range	λ	1020 – 1650			nm
Photon detection efficiency [1]	PDE	20	6	5	%
Operating voltage	V_{op}	70 – 80			V
Dark count rate [2]	DCR	7	28	112	kHz
Terminal capacitance	C_t	0.4	0.7	1.9	pF
Timing jitter [3]	TJ	300 – 400			ps
Temperature coefficient of V_{op}	γ	0.1			V/K
Output pulse amplitude [4]	V_{out}	0.5 – 1.5	0.5 – 6	0.5 – 24	mV
TEC voltage (maximum) [5]		3.5			V
TEC current (maximum) [5]		0.75			A

[1] PDE includes the fill factor in the multiple active region case

[2] At active region PDE = 20%

[3] Single photon level, FWHM

[4] 50 Ω termination, depends on PDE

[5] For PNA-208 version

PRINCIPLE OF OPERATION

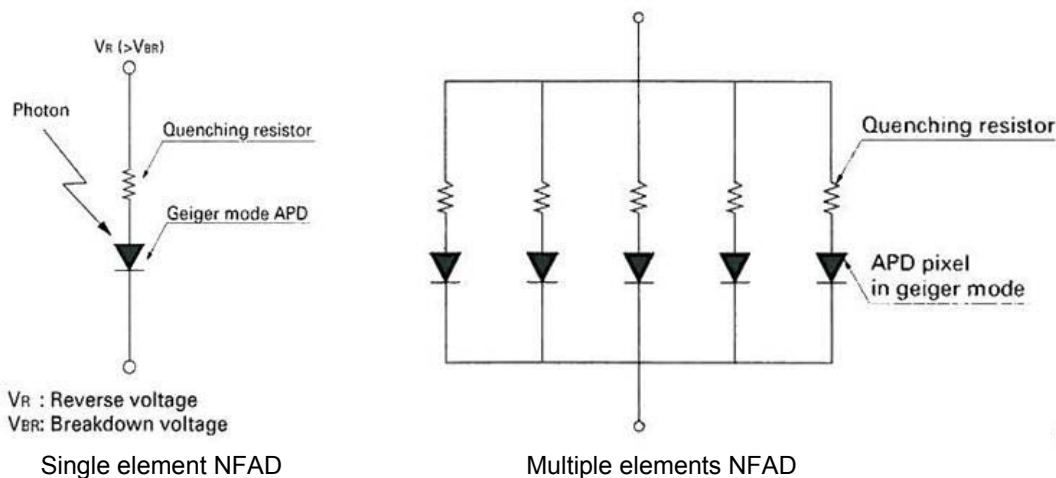

PLI's NFAD consists of single or multiple InGaAs/InP avalanche photodiodes monolithically integrated with feedback resistors. For NFAD devices consisting of multiple elements, all active regions are connected in parallel and share common cathode and anode connections. The integrated quenching resistors provide negative feedback to the Geiger mode APD, and regulate the number of charges in each elementary avalanche charge packet. When a single active region is irradiated with a photon pulse, it avalanches and outputs a charge pulse whose size is independent of the number of incident photons.

For NFADs containing multiple active regions, simultaneous output pulses from the individual active regions aggregate into a single large pulse with an amplitude proportional to the number of active regions that avalanched. When a low-level light signal is present and the probability of multiple photons irradiating the same active region is low, the number of photons can be determined from the pulse height. Through this behavior, device formats with multiple active regions have photon number resolution capability. However, they also require inactive regions between the active regions, resulting in a decreased fill factor (i.e., the ratio of active area to total illuminated area). The fill factor can be increased by customization for specific customer applications.

MECHANICAL SPECIFICATIONS: PNA-200

The PNA-200 is a 3-pin TO-46 module.

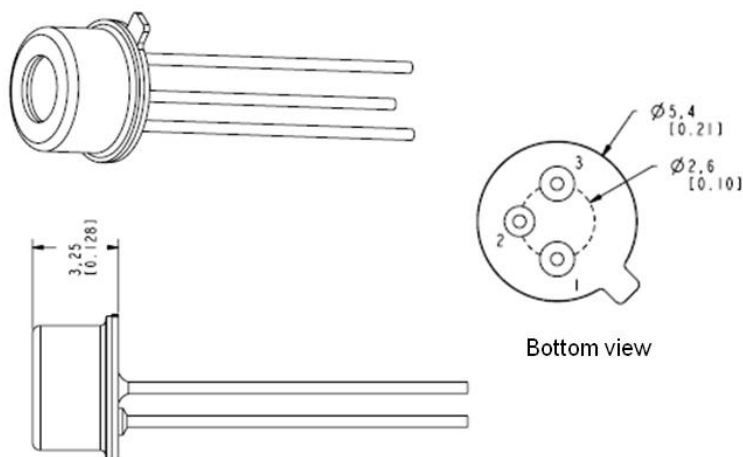

Pin	Description
1	P-contact (Anode)
2	Case ground
3	N-contact (Cathode)

TYPICAL APPLICATION CIRCUIT: PNA-200

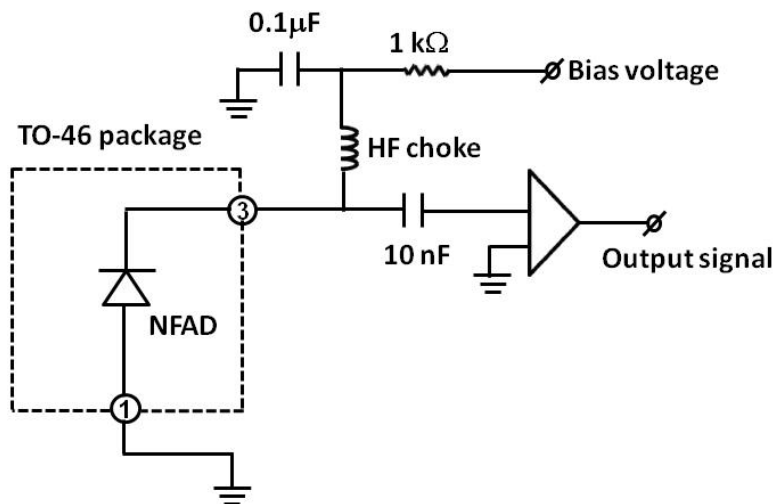

MECHANICAL SPECIFICATIONS: PNA-208

The PNA-208 is a 6-pin TO-8 module.

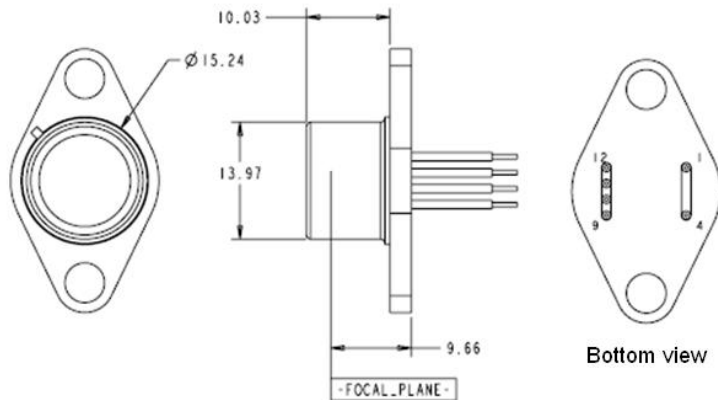

Pin	Description
1	TE Cooler (-)
4	TE Cooler (+)
9	P-contact (Anode)
10	Thermistor
11	Thermistor
12	N-contact (Cathode)

Thermistor = 1.84 k Ω at 298K, 54.55 k Ω at 223 K

Steinhart-Hart Thermistor Constants: A = 0.8642E-03, B = 3.3085E-04, C = 0.0660E-07

TYPICAL APPLICATION CIRCUIT: PNA-208

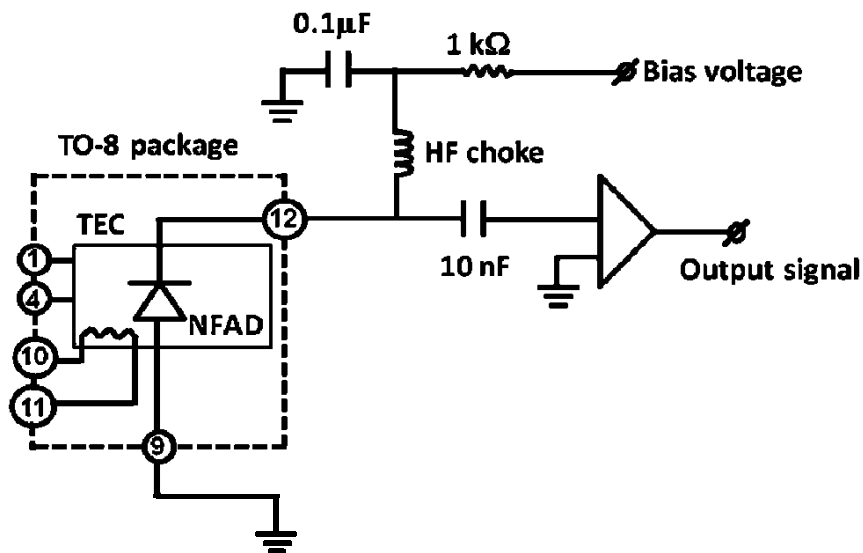

PRODUCT HANDLING

Avalanche photodiodes are sensitive to electrostatic discharge (ESD) and should be handled with appropriate caution, including the use of ESD protective equipment such as grounding straps and anti-static mats.