



Pigtailed 14 Pin Butterfly Single Photon Avalanche Diode (SPAD) PGA-400

1. PRODUCT DESCRIPTION

The Princeton Lightwave SPAD is an InGaAs/InP avalanche photodetector designed specifically for single photon counting applications. The device is intended for use at voltage biases above the breakdown voltage (in the so-called “Geiger mode”) so that a single photon incident on the detector will give rise to a macroscopic current pulse. Combined with appropriate pulse detection circuitry, this device allows for the detection of single photons in the wavelength range from 0.95 to 1.65 μm .

The SPAD described in this datasheet is a back-illuminated device provided in a pigtailed 14 pin butterfly package with a single stage thermoelectric cooler.

2. PERFORMANCE SPECIFICATIONS

Parameter Description	Test Conditions	Specifications			Unit
		Min	Typ	Max	
Linear Mode Parameters (chip temperature 295K, all voltages and currents are reverse biased)					
Breakdown voltage, V_b	Chip temperature 295K, $I_d = 10 \mu\text{A}$	50	70	90	V
Temperature dependence of V_b , γ	Between 300K and 150K, linear approximation		0.15		%/K
Quantum Efficiency, QE	1550 nm, M=1 (Linear mode) 1300 nm, M=1 (Linear mode)		60 75		%
Total Dark Current, I_d	M=10; primarily non-multiplied I_d		0.3		nA
Capacitance, C	M=10, 1 MHz		1.1		pF
Geiger Mode Parameters					
Detection Efficiency, DE	chip temperature 218 K at case temperature 233 K, 1550 nm, at DCR max	20			%
Dark Count Rate, DCR	chip temperature 218 K at case temperature 233 K, at DE min			50	kHz

3. MAXIMUM RATINGS

Parameter	Conditions	Min.	Max.	Units
Forward Current	Continuous bias		1	mA
Forward Voltage	Continuous bias		1	V
Reverse Current	Continuous bias		1	mA
Reverse Voltage	Continuous bias		$(V_b + 5)$	V
Reverse Voltage	Pulsed (gated operation)		$(V_b + 10)$	V
Optical Power	Continuous wave (CW)		1	mW
TEC Current			2	A
TEC Voltage			3.5	V
Case Temperature		-65	65	$^{\circ}\text{C}$

Maximum ratings indicate conditions that the device can be exposed to for short periods of time without damage. Although InGaAs SPADs are sometimes operated at temperatures below -60°C , these devices have not yet been tested to establish their reliability characteristics at very low temperatures and under extreme conditions of thermal cycling.

4. MECHANICAL SPECIFICATIONS

The 14 pin butterfly package contains the back-illuminated APD and is hermetically sealed. The negative temperature coefficient thermistor in the package has a nominal resistance of 2.252 k Ω . The Steinhart-Hart coefficients with 10 μ A current are:

A = 1.467852 E-03
 B = 2.382437 E-04
 C = 1.022214 E-07

Note: At -67°C the thermistor resistance value approaches 500 k Ω .

InGaAs SPAD performance is specified at a low chip temperature of -55°C. The internal TEC is capable of maintaining 15°C cooling at low case temperature, and external cooling of the butterfly package is necessary to achieve this low case temperature.

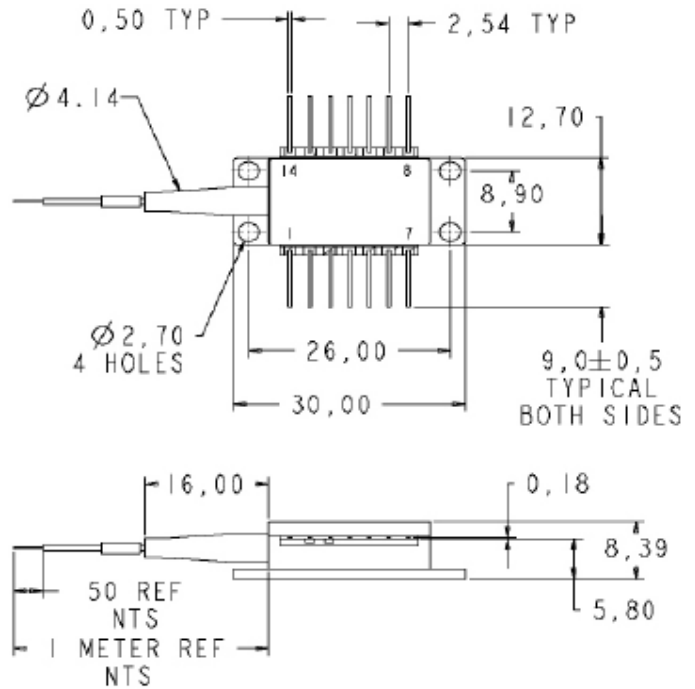

Pin	Name	Pin	Name
1	TEC (+)	8	NC
2	NC	9	NC
3	NC	10	Thermistor
4	APD Cathode	11	Thermistor
5	NC	12	NC
6	APD Anode	13	Case ground
7	NC	14	TEC (-)

5. PRODUCT HANDLING

These avalanche photodiodes are sensitive to electrostatic discharge (ESD) and should be handled with appropriate caution, including the use of ESD protective equipment such as grounding straps and anti-static mats.